

Industrial Rotary Switch

Features

- Hill and valley detent
- Balanced double bump detent spring
- 30° or 60° indexing
- Spring return styles available
- Adjustable stop available
- Solder lug and printed circuit terminals available
- Molded stator prevents solder from flowing into the circuit
- Custom switching patterns available
- Index or wafers are available separately
- RoHS compliant

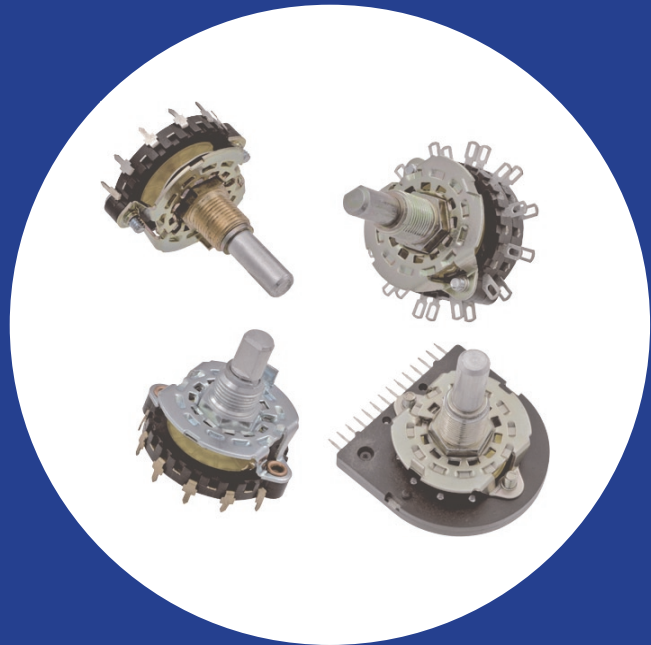

Electrical and Mechanical Specifications

Indexing

Double bump spring hill and valley detent with standard 30° indexing for 2 through 12 positions or with special 60° indexing from 2 to 6 positions.

Special 90° indexing consult CTS

Voltage and Current Rating

UL Rating: 3/4 amp at 125 VAC (shorting type only)
Special Rating: 1/4 amp at 28 VDC (shorting or non shorting)
1 amp at 28 VDC (shorting type only)

Contact Resistance

.015 ohm max. when measured from adjacent terminals

Stop Strength

15 in-lb (17.3 Kgf-cm)

Torque

Up to 48 in-oz. (3.4 Kgf-cm)

Detent Rotational Life

25,000 cycles

Materials

Shaft: Aluminum or unplated brass at CTS option

Bushing: Brass

Detent Spring: Spring brass or nickel silver depending on torque requirements

Front Plate: Zinc plated or nickel plated steel

Rotor Contacts, Stator Contacts and Terminals:
Silver plated brass standard

Stator Insulator: Glass reinforced thermoset material

Bushing Lengths

Standard: 3/8"-32 UNEF-2A Thread, 1/4" (6.35mm) or 3/8" (9.53mm) long.

Special Lengths: Available as required

Locating Lugs

Standard: Left side .531" (13.5mm) radius

Special: Right side .531" (13.5mm) radius or no lug

Shaft Trim

Standard: Plain round, Flat, Slot, Knurl, or mixed (Flat with Slot)

Special: Available as request

Frames

Machine screw, bolt & nut, or rivet construction

Physical Dimensions

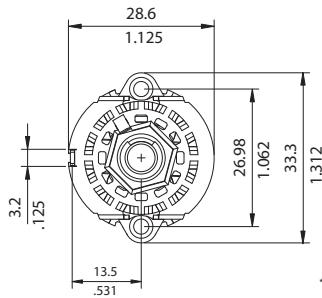
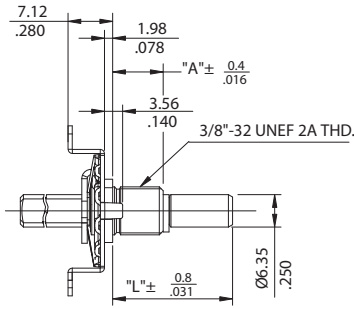

* NOTE :
10.82/426 DIMENSION BASED UPON USE OF ONE 6.35/250
NO SPACERS OR SPACERS OF NUMEROUS LENGTHS
ARE AVAILABLE TO PROVIDE PIN SPACINGS AS REQ'D .

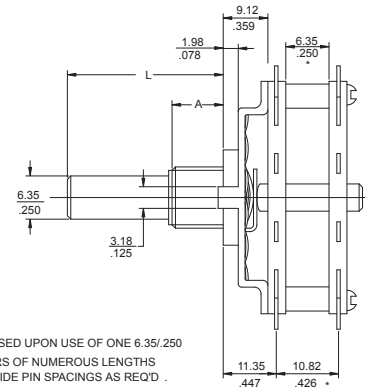

DIMENSION: $\frac{\text{mm}}{\text{inch}}$

Detent Only

Typical Assembled Switch

Available Terminal Styles

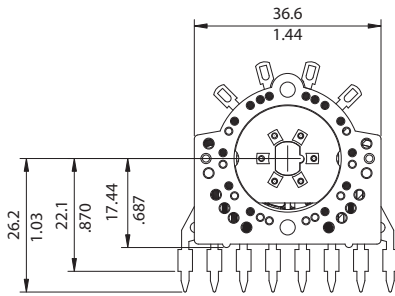

Y-Style

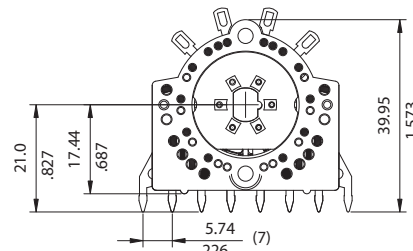

X-Style

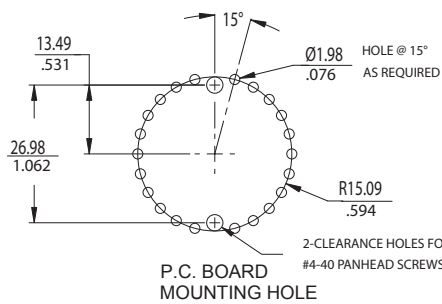

P.C. BOARD MOUNTING HOLE

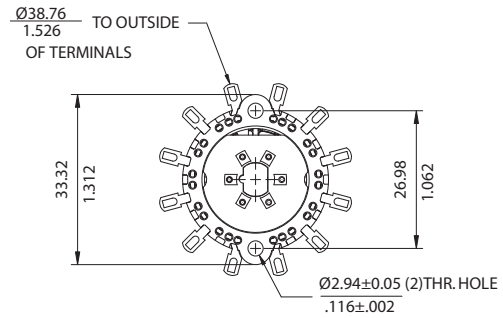

T-Style

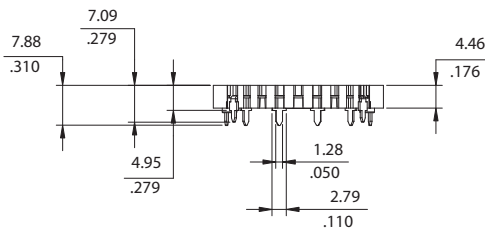

U-Style

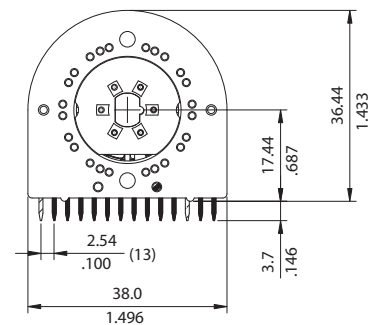

P-Style

DIMENSION: $\frac{\text{mm}}{\text{inch}}$

Ordering Information

