

Model CV Series

Advanced PLL HCMOS, LVPECL or LVDS VCXO

Features

- Ceramic Surface Mount Package
- Very Low Phase Jitter Performance, 150fs Typical
- Quartz Crystal Based Design
- Frequency Range to 2.1GHz *
- +1.8V, +2.5V or +3.3V Operation
- Output Enable Standard
- Tape and Reel Packaging, EIA-481

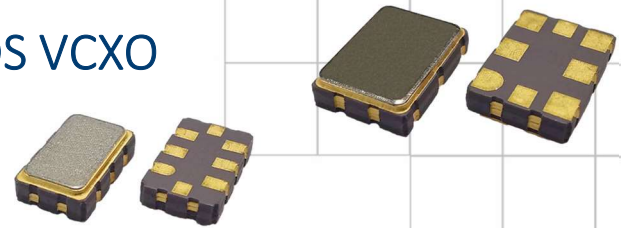

Part Dimensions:
 5.0 × 3.2 × 1.5mm • 61.8mg
 7.0 × 5.0 × 1.9mm • 172.74mg

Applications

- SerDes
- Storage Area Networking
- Broadband Access
- SONET/SDH/DWDM
- PON
- Ethernet/Gbe/SyncE
- Fiber Channel
- Medical Electronics
- Test and Measurement

Description

CTS Model CV Series is a high-performance clock oscillator supporting HCMOS and differential LVPECL or LVDS outputs. Employing the latest IC technology, CV Series has excellent stability and low jitter/phase noise performance.

Ordering Information

Model	Package Size	Output Type	Absolute Pull Range (APR)	Temperature Range	Supply Voltage	Frequency Code (MHz)	Packaging																								
CV	S	C	B	I	L	1244M16000	T																								
	<table border="1"> <thead> <tr> <th>Code</th> <th>Dimensions</th> </tr> </thead> <tbody> <tr> <td>5</td> <td>5.0mmx3.2mm</td> </tr> <tr> <td>7</td> <td>7.0mmx5.0mm</td> </tr> </tbody> </table>	Code	Dimensions	5	5.0mmx3.2mm	7	7.0mmx5.0mm		<table border="1"> <thead> <tr> <th>Code</th> <th>Voltage</th> </tr> </thead> <tbody> <tr> <td>B</td> <td>±50ppm</td> </tr> <tr> <td>D</td> <td>±100ppm</td> </tr> </tbody> </table>	Code	Voltage	B	±50ppm	D	±100ppm		<table border="1"> <thead> <tr> <th>Code</th> <th>Voltage</th> </tr> </thead> <tbody> <tr> <td>M</td> <td>+1.8Vdc²</td> </tr> <tr> <td>N</td> <td>+2.5Vdc</td> </tr> <tr> <td>L</td> <td>+3.3Vdc</td> </tr> </tbody> </table>	Code	Voltage	M	+1.8Vdc ²	N	+2.5Vdc	L	+3.3Vdc		<table border="1"> <thead> <tr> <th>Code</th> <th>Packing</th> </tr> </thead> <tbody> <tr> <td>T</td> <td>1k pcs./reel</td> </tr> </tbody> </table>	Code	Packing	T	1k pcs./reel
Code	Dimensions																														
5	5.0mmx3.2mm																														
7	7.0mmx5.0mm																														
Code	Voltage																														
B	±50ppm																														
D	±100ppm																														
Code	Voltage																														
M	+1.8Vdc ²																														
N	+2.5Vdc																														
L	+3.3Vdc																														
Code	Packing																														
T	1k pcs./reel																														
		<table border="1"> <thead> <tr> <th>Code</th> <th>Output</th> </tr> </thead> <tbody> <tr> <td>C</td> <td>HCMOS</td> </tr> <tr> <td>P</td> <td>LVPECL</td> </tr> <tr> <td>L</td> <td>LVDS</td> </tr> </tbody> </table>	Code	Output	C	HCMOS	P	LVPECL	L	LVDS	<table border="1"> <thead> <tr> <th>Code</th> <th>Temp. Range</th> </tr> </thead> <tbody> <tr> <td>C</td> <td>-20°C to +70°C</td> </tr> <tr> <td>I</td> <td>-40°C to +85°C</td> </tr> </tbody> </table>	Code	Temp. Range	C	-20°C to +70°C	I	-40°C to +85°C	<table border="1"> <thead> <tr> <th>Code</th> <th>Frequency (MHz)¹</th> </tr> </thead> <tbody> <tr> <td>1244M16000</td> <td>1244.16000</td> </tr> </tbody> </table>	Code	Frequency (MHz) ¹	1244M16000	1244.16000									
Code	Output																														
C	HCMOS																														
P	LVPECL																														
L	LVDS																														
Code	Temp. Range																														
C	-20°C to +70°C																														
I	-40°C to +85°C																														
Code	Frequency (MHz) ¹																														
1244M16000	1244.16000																														

Notes:

- 1] Frequency is recorded with 4 leading significant digits [including zeros] before and 6 significant digits [including zeroes] after the "M".
 [Ex. 1244.16000MHz = 1244M16000, 156.25000MHz = 0156M25000, 608.75000MHz = 0608M75000]
- 2] HCMOS and LVDS outputs only.

**Not all performance combinations and frequencies may be available.
 Contact your local CTS Representative or CTS Customer Service for availability.**

This product is specified for use only in standard commercial applications. Supplier disclaims all express and implied warranties and liability in connection with any use of this product in any non-commercial applications or in any application that may expose the product to conditions that are outside of the tolerances provided in its specification.



Electrical Specifications

Operating Conditions

PARAMETER	SYMBOL	CONDITIONS	MIN	TYP	MAX	UNIT
Maximum Supply Voltage	V_{CC}	-	-0.5	-	3.8	V
Maximum Control Voltage	V_C	V_{CC} = nominal	-0.5	-	3.8	V
Supply Voltage	V_{CC}	$\pm 5\%$, HCMOS & LVDS only	1.71	1.8	1.89	
		$\pm 10\%$	2.25	2.5	2.75	V
Supply Current						
HCMOS	I_{CC}	Maximum Load	-	80	-	
LVPECL		Maximum Current Value @ +3.3V	-	100	120	mA
LVDS			-	75	90	
Operating Temperature	T_A	-	-20	+25	+70	$^{\circ}C$
Storage Temperature	T_{STG}	-	-40	-	+85	$^{\circ}C$
			-55	-	+125	$^{\circ}C$

Frequency Stability

PARAMETER	SYMBOL	CONDITIONS	MIN	TYP	MAX	UNIT
Frequency Range	f_0	HCMOS		15 - 250		MHz
		LVPECL/LVDS		15 - 2,100		
Frequency Stability [Note 1]	$\Delta f/f_0$	-		25		\pm ppm
Aging	$\Delta f/f_{25}$	First Year @ +25 $^{\circ}C$, nominal V_{CC}	-3	-	3	ppm

1.] Inclusive of initial tolerance at time of shipment, changes in supply voltage, load, temperature and 1st year aging.

Output Parameters

PARAMETER	SYMBOL	CONDITIONS	MIN	TYP	MAX	UNIT
Output Type	-	-	HCMOS			-
Output Load	C_L	-	-	-	15	pF
Output Voltage Levels	V_{OH}	CMOS Load	$V_{CC} - 0.4V$	-	-	
	V_{OL}	CMOS Load	-	-	$0.1V_{CC}$	V
Output Duty Cycle	SYM	@ 50% Level, +2.5V and +3.3V	45	-	55	%
		@ 50% Level, +1.8V	40	-	60	
Rise and Fall Time	T_R, T_F	@ 10%/90% Levels, $C_L = 15pF$	-	-	5	ns
Output Type	-	-	LVPECL			-
Output Load	R_L	Terminated to $V_{CC} - 2.0V$	-	50	-	Ohms
Output Voltage Levels	V_{OH}	PECL Load	$V_{CC} - 1.165$	-	$V_{CC} - 0.80$	V
	V_{OL}		$V_{CC} - 2.0$	-	$V_{CC} - 1.55$	
Output Duty Cycle	SYM	@ $V_{CC} - 1.3V$	45	-	55	%
Differential Output Voltage	V_{OD}	$R_L = 50$ Ohms	595	-	930	mV
Rise and Fall Time	T_R, T_F	@ 20%/80% Levels, $R_L = 50$ Ohms	-	-	0.40	ns



Electrical Specifications

Output Parameters

PARAMETER	SYMBOL	CONDITIONS	MIN	TYP	MAX	UNIT
Output Type	-	-		LVDS		-
Output Load	R_L	Between Outputs	-	100	-	Ohms
Output Voltage Levels	V_{OH}	LVDS Load	-	1.40	1.60	V
	V_{OL}		0.90	1.10	-	
Output Duty Cycle	SYM	@ 1.25V	45	-	55	%
Differential Output Voltage	V_{OD}	$R_L = 100$ Ohms	250	-	450	mV
Offset Voltage	V_{OS}	LVDS Load	1.20	1.25	1.30	V
Rise and Fall Time	T_R, T_F	@ 20%/80% Levels, $R_L = 100$ Ohms	-	-	0.40	ns

PARAMETER	SYMBOL	CONDITIONS	MIN	TYP	MAX	UNIT
Start Up Time	T_S	Application of V_{CC}	-	5	10	ms
Enable Function [Tri-State]						
Enable Input Voltage	V_{IH}	Pin 2 Logic '1', Output Enabled	$0.8V_{CC}$	-	-	V
Disable Input Voltage	V_{IL}	Pin 2 Logic '0', Output Disabled	-	-	$0.2V_{CC}$	V
		Pin 2 Logic '0', Output Disabled, HCMOS	-	63	-	
Disable Current	I_{IL}	Pin 2 Logic '0', Output Disabled, LVPECL	-	99	-	mA
		Pin 2 Logic '0', Output Disabled, LVDS	-	74	-	
Disable Time	T_{PLZ}	Pin 2 Logic '0', Output Disabled	-	-	10	μ s
Enable Time	T_{PLZ}	Pin 2 Logic '1', Output Enabled	-	-	2.5	ms
Phase Jitter, RMS	t_{jrms}	Bandwidth 12 kHz - 20 MHz	-	150	300	fs

Control Voltage

PARAMETER	SYMBOL	CONDITIONS	MIN	TYP	MAX	UNIT
Control Voltage	V_C	$V_{CC} = +1.8V$, LVDS only	0.0	0.90	1.8	
		$V_{CC} = +2.5V$	0.25	1.25	2.25	V
		$V_{CC} = +3.3V$	0.3	1.65	3.0	
Frequency Pulling Range	$\Delta f/f_0$	V_C range	± 100 or ± 150 minimum			ppm
Linearity	L	Best Straight Line Fit	-	-	± 10	%
Gain Transfer	K_V	Pull Sensitivity; @ +1.25V, +25°C	-	80	260	ppm/V
		Pull Sensitivity; @ +1.65V, +25°C				
Input Impedance	Z_{Vc}	-	5	-	-	MOhms
Modulation Roll-off	-	@ -3dB	10	-	-	kHz
Transfer Function	-	-		Positive		-

Enable Truth Table

HCMOS

Pin 2	Pin 4
Logic '1'	Output Enabled
Open	Output Enabled
Logic '0'	Output Disabled, High Impedance

Enable Truth Table

LVPECL or LVDS

Pin 2	Pin 4 & Pin 5
Logic '1'	Output Enabled
Open	Output Enabled
Logic '0'	Output Disabled, High Impedance

Electrical Specifications

Output Waveform

HCMOS

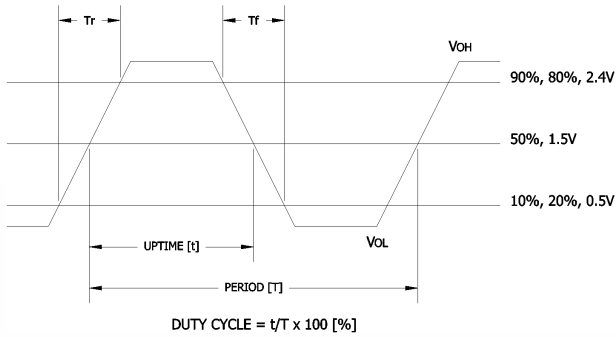

Output Waveform

LVPECL or LVDS

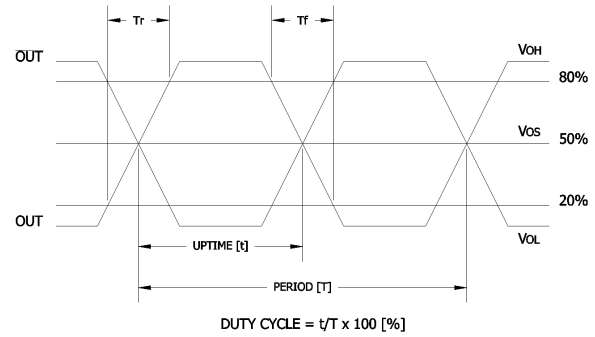

Test Circuits

HCMOS

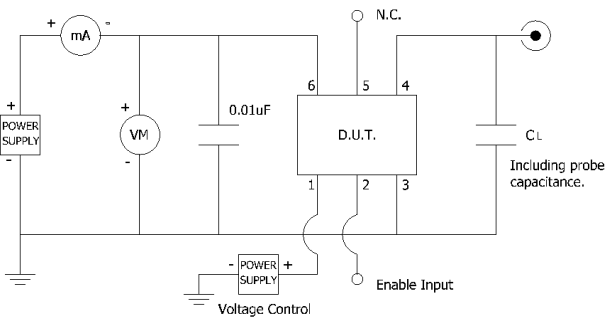

LVPECL

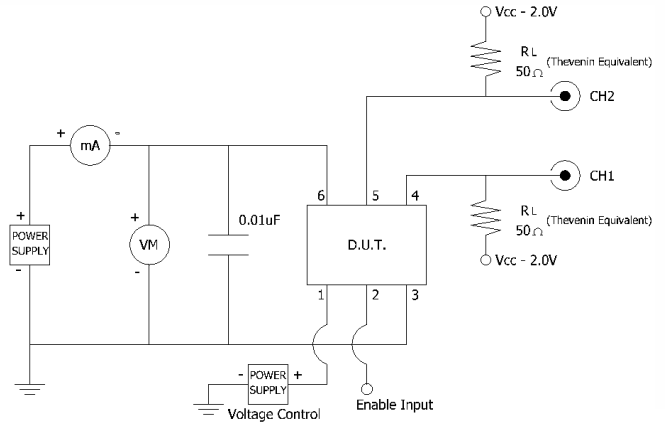

LVDS

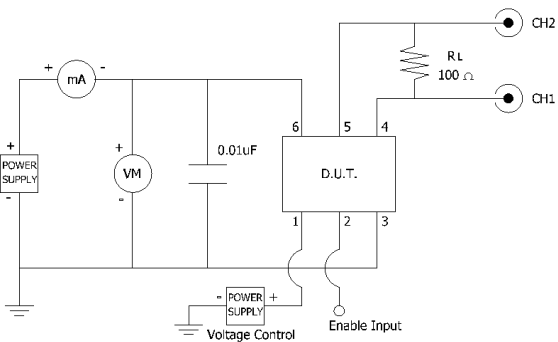

LVDS @ +1.8V

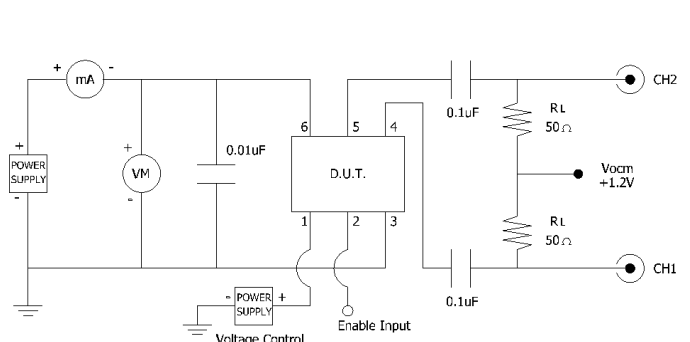



Electrical Specifications

Performance Data

Phase Noise [typical]

100MHz, $V_{CC} = +3.3V$, $T_A = +25^\circ C$

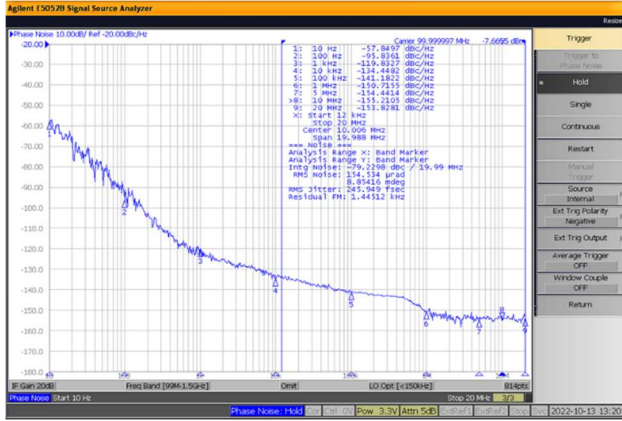

106.25MHz, $V_{CC} = +3.3V$, $T_A = +25^\circ C$

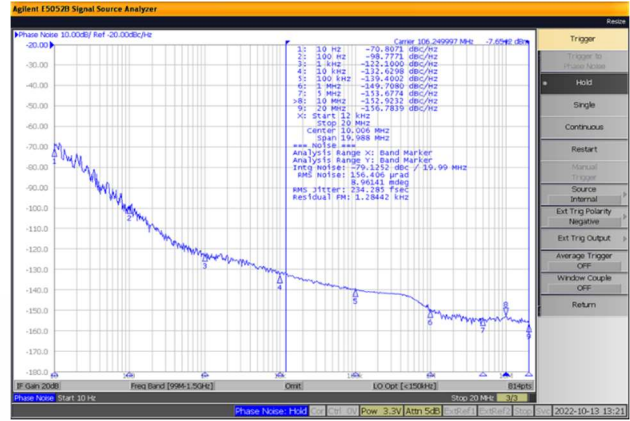

122.88MHz, $V_{CC} = +3.3V$, $T_A = +25^\circ C$

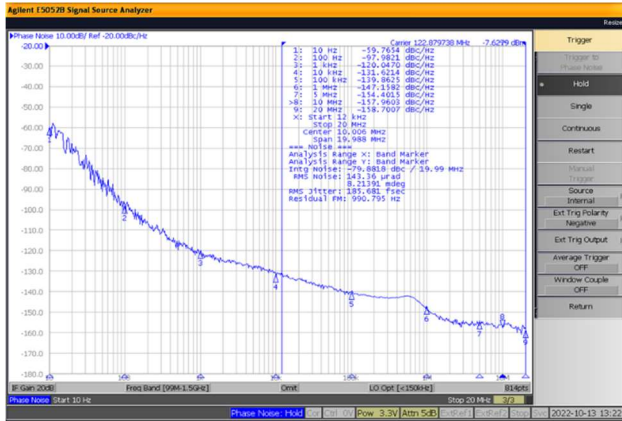

125MHz, $V_{CC} = +3.3V$, $T_A = +25^\circ C$

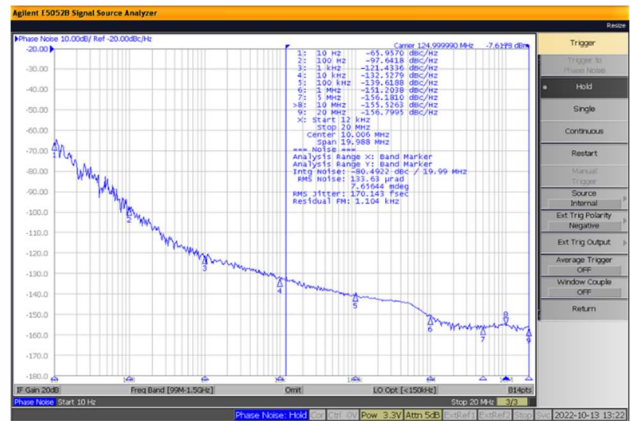

150MHz, $V_{CC} = +3.3V$, $T_A = +25^\circ C$

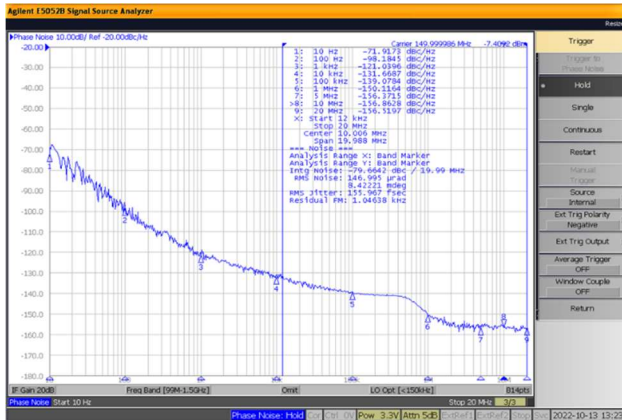

156.25MHz, $V_{CC} = +3.3V$, $T_A = +25^\circ C$

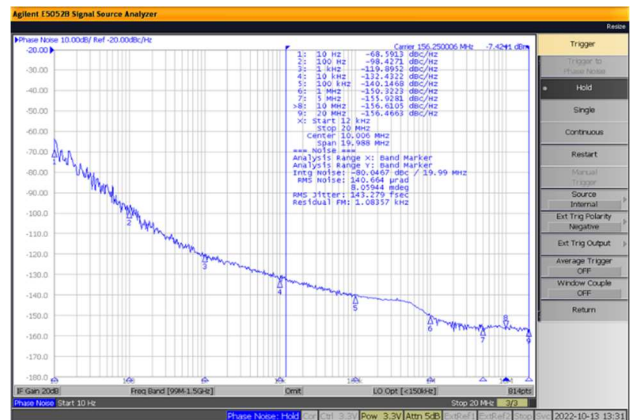



Electrical Specifications

Performance Data

Phase Noise [typical]

200MHz, $V_{CC} = +3.3V$, $T_A = +25^\circ C$

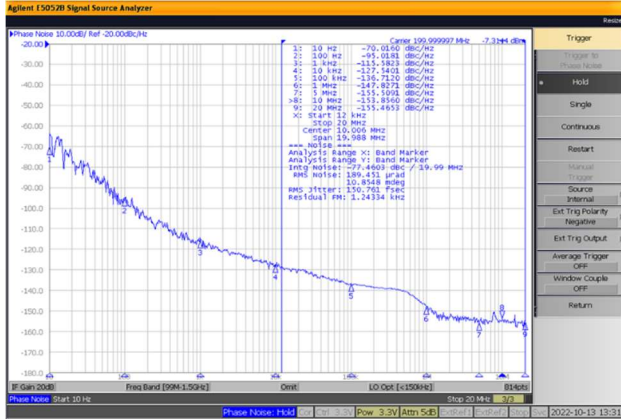

212.5MHz, $V_{CC} = +3.3V$, $T_A = +25^\circ C$

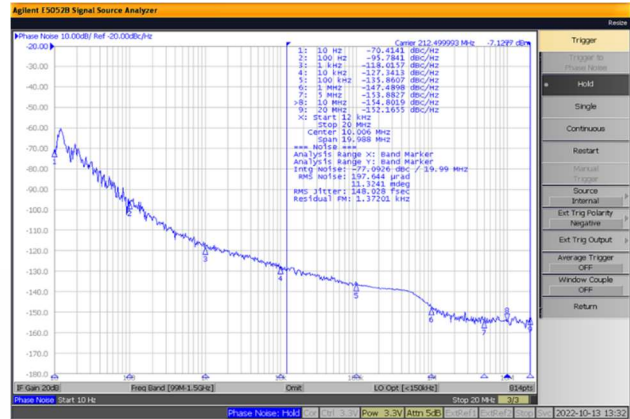

250MHz, $V_{CC} = +3.3V$, $T_A = +25^\circ C$

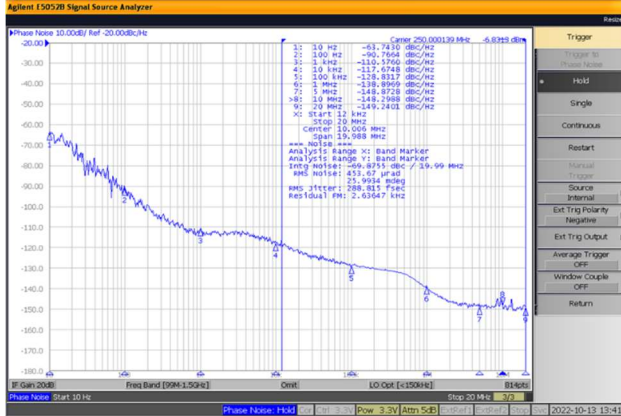

312.5MHz, $V_{CC} = +3.3V$, $T_A = +25^\circ C$

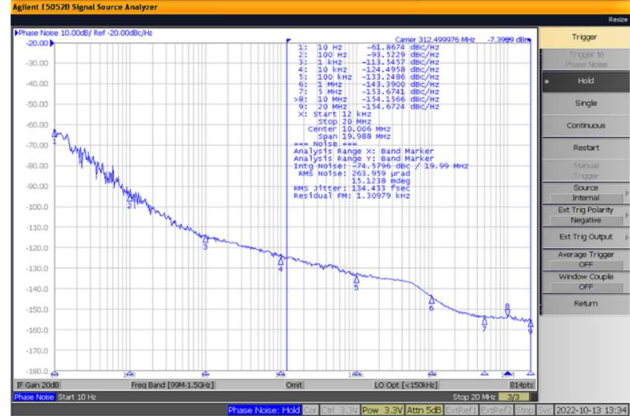

622.08MHz, $V_{CC} = +3.3V$, $T_A = +25^\circ C$

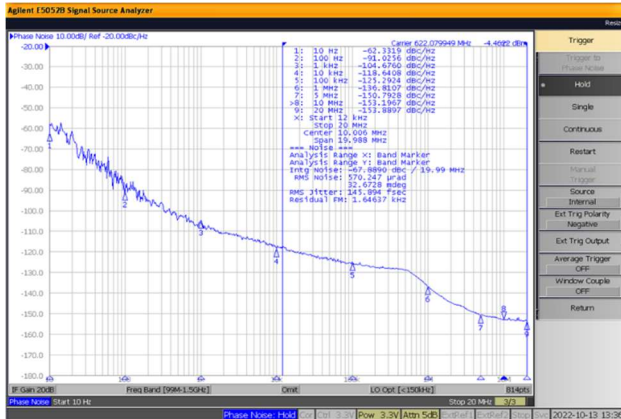

644.53125MHz, $V_{CC} = +3.3V$, $T_A = +25^\circ C$

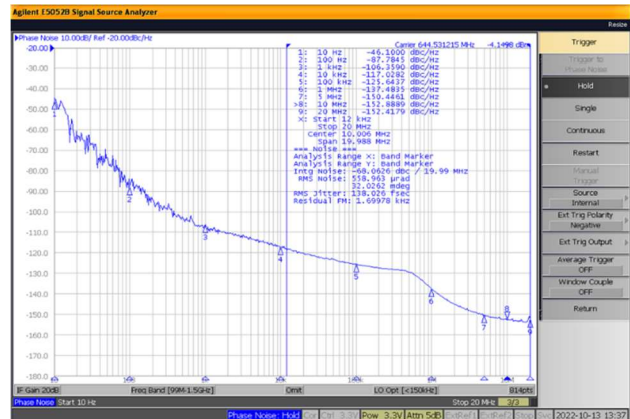



Electrical Specifications

Performance Data

Phase Noise Tabulated

Typical, $V_{CC} = +3.3V$, $T_A = +25^{\circ}C$

PARAMETER	SYMBOL	CONDITIONS	TYP	UNIT	
100.0000MHz					
Phase Noise	-	Single Side Band			
		@ 10Hz	-57.8497		
		@ 100Hz	-95.8361		
		@ 1kHz	-119.8327		
		@ 10kHz	-134.4482	dBc/Hz	
		@ 100kHz	-141.1822		
		@ 1MHz	-150.7155		
		@ 5MHz	-154.4414		
		@ 10MHz	-155.2105		
@ 20MHz	-153.8281				
Phase Jitter, RMS	tjrms	Integration Bandwidth 12kHz - 20MHz	245.9490		fs

PARAMETER	SYMBOL	CONDITIONS	TYP	UNIT	
122.8800MHz					
Phase Noise	-	Single Side Band			
		@ 10Hz	-59.7654		
		@ 100Hz	-97.9821		
		@ 1kHz	-120.0470		
		@ 10kHz	-131.6214	dBc/Hz	
		@ 100kHz	-139.8625		
		@ 1MHz	-147.1582		
		@ 5MHz	-154.4015		
		@ 10MHz	-157.9603		
@ 20MHz	-158.7007				
Phase Jitter, RMS	tjrms	Integration Bandwidth 12kHz - 20MHz	185.6810		fs

PARAMETER	SYMBOL	CONDITIONS	TYP	UNIT	
150.0000MHz					
Phase Noise	-	Single Side Band			
		@ 10Hz	-71.9173		
		@ 100Hz	-98.1845		
		@ 1kHz	-121.0396		
		@ 10kHz	-131.6687	dBc/Hz	
		@ 100kHz	-139.0784		
		@ 1MHz	-150.1164		
		@ 5MHz	-156.3715		
		@ 10MHz	-156.8628		
@ 20MHz	-156.5197				
Phase Jitter, RMS	tjrms	Integration Bandwidth 12kHz - 20MHz	155.9670		fs

Typical, $V_{CC} = +3.3V$, $T_A = +25^{\circ}C$

PARAMETER	SYMBOL	CONDITIONS	TYP	UNIT	
106.2500MHz					
Phase Noise	-	Single Side Band			
		@ 10Hz	-70.8071		
		@ 100Hz	-98.7771		
		@ 1kHz	-122.1000		
		@ 10kHz	-132.6298	dBc/Hz	
		@ 100kHz	-139.4002		
		@ 1MHz	-149.7080		
		@ 5MHz	-153.6774		
		@ 10MHz	-152.9232		
@ 20MHz	-156.7839				
Phase Jitter, RMS	tjrms	Integration Bandwidth 12kHz - 20MHz	234.2850		fs

PARAMETER	SYMBOL	CONDITIONS	TYP	UNIT	
125.0000MHz					
Phase Noise	-	Single Side Band			
		@ 10Hz	-65.9570		
		@ 100Hz	-97.6418		
		@ 1kHz	-121.4336		
		@ 10kHz	-132.5279	dBc/Hz	
		@ 100kHz	-139.6188		
		@ 1MHz	-151.2038		
		@ 5MHz	-156.1810		
		@ 10MHz	-155.5263		
@ 20MHz	-156.7995				
Phase Jitter, RMS	tjrms	Integration Bandwidth 12kHz - 20MHz	170.1430		fs

PARAMETER	SYMBOL	CONDITIONS	TYP	UNIT	
156.2500MHz					
Phase Noise	-	Single Side Band			
		@ 10Hz	-68.5913		
		@ 100Hz	-98.4271		
		@ 1kHz	-119.8952		
		@ 10kHz	-132.4322	dBc/Hz	
		@ 100kHz	-140.1468		
		@ 1MHz	-150.3223		
		@ 5MHz	-155.9281		
		@ 10MHz	-156.6105		
@ 20MHz	-156.4663				
Phase Jitter, RMS	tjrms	Integration Bandwidth 12kHz - 20MHz	143.2790		fs



Electrical Specifications

Performance Data

Phase Noise Tabulated

Typical, $V_{CC} = +3.3V$, $T_A = +25^\circ C$

PARAMETER	SYMBOL	CONDITIONS	TYP	UNIT	
200.0000MHz					
Phase Noise		Single Side Band			
		@ 10Hz	-70.0160		
		@ 100Hz	-95.0181		
		@ 1kHz	-115.5823		
		@ 10kHz	-127.5401	dBc/Hz	
		@ 100kHz	-136.7120		
		@ 1MHz	-147.8271		
		@ 5MHz	-155.5091		
		@ 10MHz	-153.8560		
	@ 20MHz	-155.4653			
Phase Jitter, RMS	tjrms	Integration Bandwidth 12kHz - 20MHz	150.7610		fs

PARAMETER	SYMBOL	CONDITIONS	TYP	UNIT	
250.0000MHz					
Phase Noise		Single Side Band			
		@ 10Hz	-63.7430		
		@ 100Hz	-90.7664		
		@ 1kHz	-110.5760		
		@ 10kHz	-117.6748	dBc/Hz	
		@ 100kHz	-128.8317		
		@ 1MHz	-138.8969		
		@ 5MHz	-148.8728		
		@ 10MHz	-148.2933		
	@ 20MHz	-149.2401			
Phase Jitter, RMS	tjrms	Integration Bandwidth 12kHz - 20MHz	288.8150		fs

PARAMETER	SYMBOL	CONDITIONS	TYP	UNIT	
622.0800MHz					
Phase Noise		Single Side Band			
		@ 10Hz	-62.3319		
		@ 100Hz	-91.0256		
		@ 1kHz	-104.6760		
		@ 10kHz	-118.6408	dBc/Hz	
		@ 100kHz	-125.2924		
		@ 1MHz	-136.8107		
		@ 5MHz	-150.7928		
		@ 10MHz	-153.1967		
	@ 20MHz	-153.8897			
Phase Jitter, RMS	tjrms	Integration Bandwidth 12kHz - 20MHz	145.8940		fs

Typical, $V_{CC} = +3.3V$, $T_A = +25^\circ C$

PARAMETER	SYMBOL	CONDITIONS	TYP	UNIT	
212.5000MHz					
Phase Noise		Single Side Band			
		@ 10Hz	-70.4141		
		@ 100Hz	-95.7841		
		@ 1kHz	-118.0157		
		@ 10kHz	-127.3413	dBc/Hz	
		@ 100kHz	-135.8607		
		@ 1MHz	-147.4898		
		@ 5MHz	-153.8827		
		@ 10MHz	-154.8019		
	@ 20MHz	-152.1655			
Phase Jitter, RMS	tjrms	Integration Bandwidth 12kHz - 20MHz	148.0280		fs

PARAMETER	SYMBOL	CONDITIONS	TYP	UNIT	
312.5000MHz					
Phase Noise		Single Side Band			
		@ 10Hz	-61.8674		
		@ 100Hz	-93.5229		
		@ 1kHz	-113.5457		
		@ 10kHz	-124.4958	dBc/Hz	
		@ 100kHz	-133.2486		
		@ 1MHz	-143.3900		
		@ 5MHz	-153.6741		
		@ 10MHz	-154.1566		
	@ 20MHz	-154.6724			
Phase Jitter, RMS	tjrms	Integration Bandwidth 12kHz - 20MHz	134.4330		fs

PARAMETER	SYMBOL	CONDITIONS	TYP	UNIT	
644.53125MHz					
Phase Noise		Single Side Band			
		@ 10Hz	-46.1000		
		@ 100Hz	-87.7845		
		@ 1kHz	-106.3590		
		@ 10kHz	-117.0282	dBc/Hz	
		@ 100kHz	-125.6437		
		@ 1MHz	-137.4835		
		@ 5MHz	-150.4461		
		@ 10MHz	-152.8889		
	@ 20MHz	-152.4179			
Phase Jitter, RMS	tjrms	Integration Bandwidth 12kHz - 20MHz	138.0260		fs

Mechanical Specifications

Package Drawing

CV5

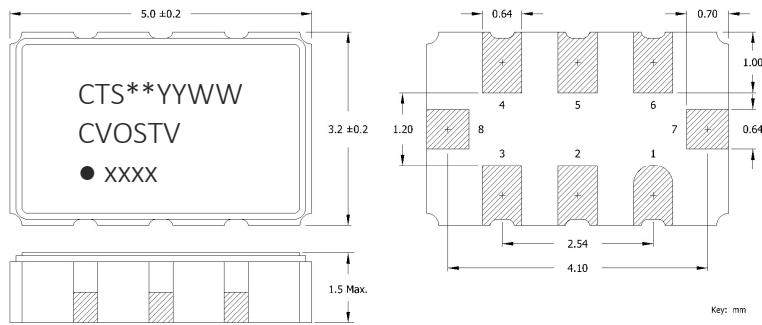

CV7

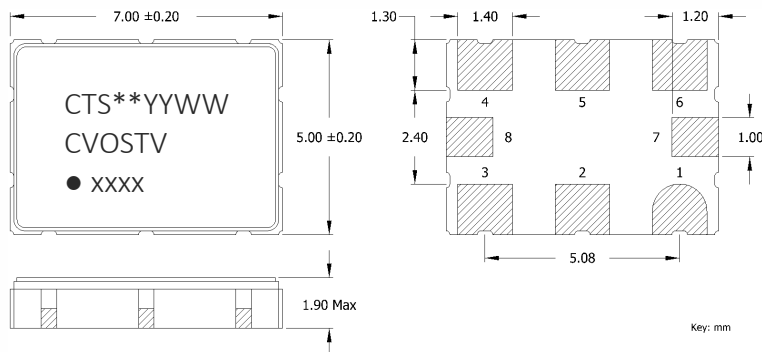

Marking Information

CV5 and CV7

- ** - Manufacturing Site Code.
- YYWW – Date Code; YY – year, WW – week.
- CV – Model series.
- O – Output Type; C = HCMOS, P = LVPECL, L = LVDS.
- ST – Frequency Stability/Temperature Code.
[Refer to Ordering Information]
- V – Voltage Code; M = 1.8V, N = 2.5V, L = 3.3V.
- xxxx – Frequency Code.
3-digits, frequencies below 100MHz
4-digits, frequencies 100MHz or greater
[See document 016-1454-0, Frequency Code Tables.]

Notes

- JEDEC termination code (e4). Barrier-plating is nickel [Ni] with gold [Au] flash plate.
- Reflow conditions per JEDEC J-STD-020; +260°C maximum, 20 seconds.
- MSL = 1.

Mechanical Specifications

Recommended Pad Layout

CV5

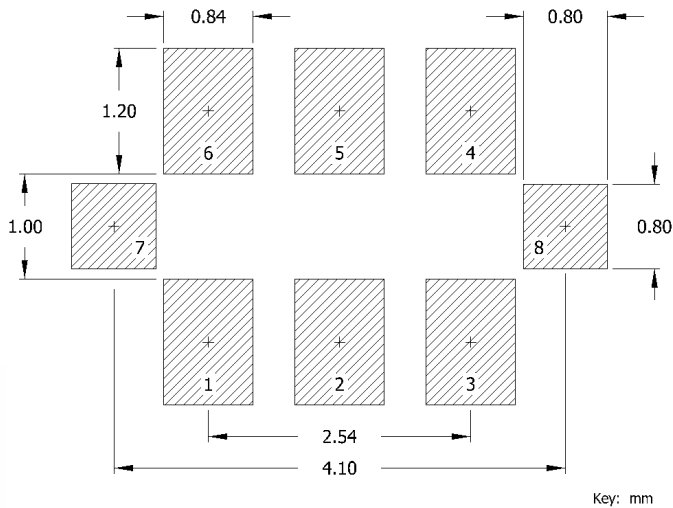

CV7

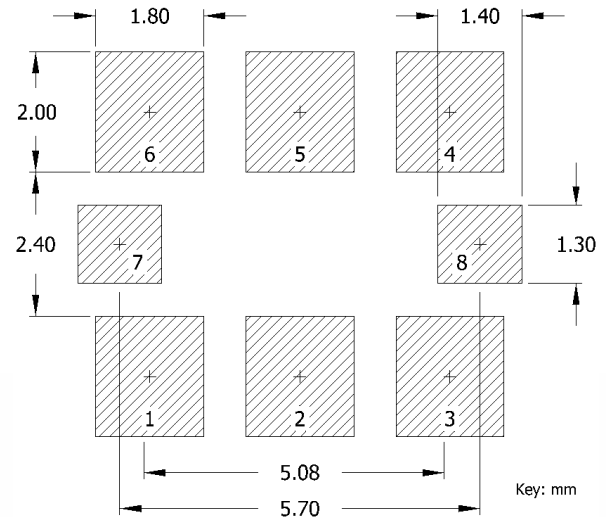

Pin Assignments

HCMOS

Pin	Symbol	Function
1	Vc	Voltage Control
2	EOH	Enable
3	GND	Circuit & Package Ground
4	Output	RF Output
5	N.C.	No Connect
6	V _{CC}	Supply Voltage
7	N.C.	Do Not Connect
8	N.C.	Do Not Connect

Pin Assignments

LVPECL or LVDS

Pin	Symbol	Function
1	Vc	Voltage Control
2	EOH	Enable
3	GND	Circuit & Package Ground
4	Output	RF Output
5	Output	Complimentary RF Output
6	V _{CC}	Supply Voltage
7	N.C.	Do Not Connect
8	N.C.	Do Not Connect

VOLTAGE SUPPLY - BYPASS CAPACITOR

Proper filtering of high frequency noise riding on the voltage supply line is critical to eliminating the injecting of that noise into the oscillator and throughout the system. It is recommended that a 0.1 μ F [100nF] capacitor be inserted from the V_{CC} pin to circuit ground. The bypass capacitor placement should be as close to the V_{CC} pad as possible with a short trace routing to circuit ground.

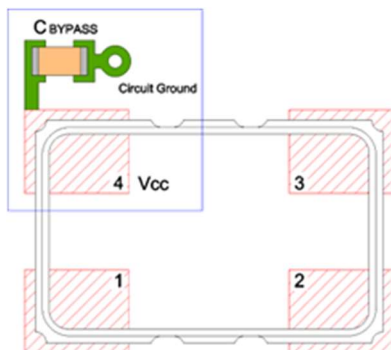

Mechanical Specifications

Table I - Date Code, Beginning year 2021

MONTH					JAN	FEB	MAR	APR	MAY	JUN	JUL	AUG	SEP	OCT	NOV	DEC
YEAR																
2021	2025	2029	2033	2037	A	B	C	D	E	F	G	H	J	K	L	M
2022	2026	2030	2034	2038	N	P	Q	R	S	T	U	V	W	X	Y	Z
2023	2027	2031	2035	2039	a	b	c	d	e	f	g	h	j	k	l	m
2024	2028	2032	2036	2040	n	p	q	r	s	t	u	v	w	x	y	z

Packaging - Tape and Reel

Tape Drawing

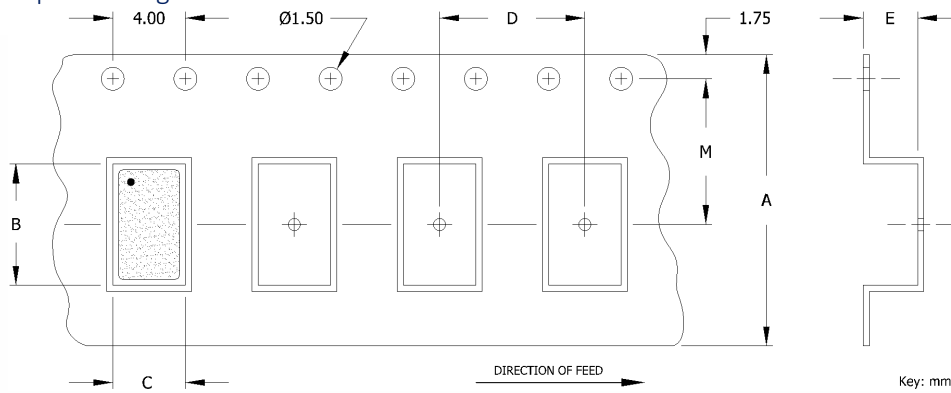

Reel Drawing

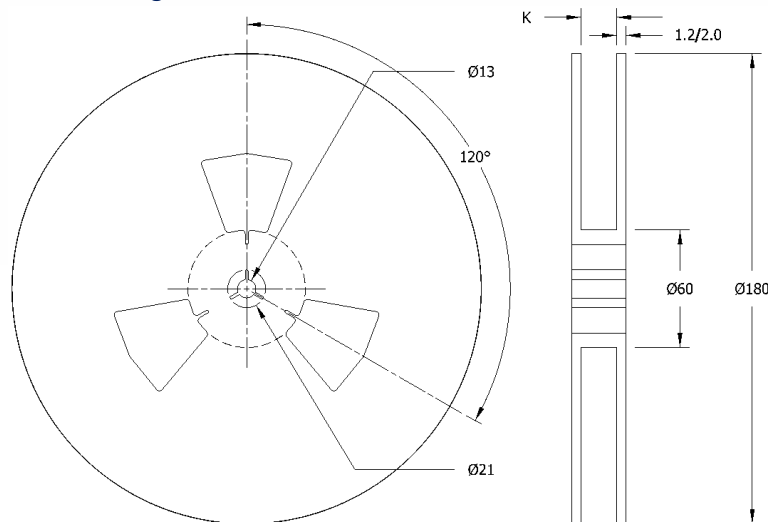

Tape Dimensions

PACKAGE	A	B	C	D	E	M	QUANTITY
CV5	12.00	5.30	3.60	8.00	1.40	5.50	1000
CV7	16.00	7.30	5.30	8.00	1.90	7.50	1000

Reel Dimensions

K
13.00
17.20

Notes

- Complete CTS part number, frequency value and date code information must appear on reel and carton labels.