

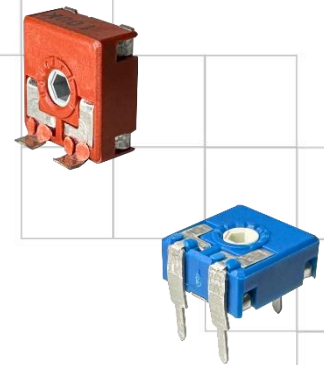

Series 09TR

9 mm Trimmer Potentiometer

- Terminals: tinned brass or tinned steel.
- Flexible gull-wing / through hole / "J" bend terminal configurations
- Various rotor types and with optional shaft & Wheel configurations
- IP 54 according to IEC 60529



Description

9 mm carbon potentiometers with plastic housing. Plastic materials can be self-extinguishable according to UL 94 V-0 upon request. This product is ideal for dimmers, volume/lighting regulation, timers and relays in industrial, electronics and automotive applications.

Ordering Information

Series	Rotor	Model	Taper	Resistance Value	Tol.	Terminal Material	Packg.	Special Request*	
09TR	01	A	A	101	A	P	R	Extra Features	Assembled Accessories
Rotor type (Page 4) 01: C-type 02: D-type 03: E-type 04: J-type 05: K-type 06: M-type 07: P-type 08: KA-type 09: MA-type 10: MT-type 11: R-type 12: Y-type		Model type (Page 4-6) A: H2.5 B: H3.8 C: HS3.8 D: H5 E: HSMD F: V7.5 G: V10 H: VK10 J: VR10 K: VSMD		Resistance Value 101:100Ω 201:200Ω ... 505:5MΩ		Terminal Material P: Tinned brass S: Tinned steel (Only available for Through-hole models)		Extra Features Life (standard 1,000 cycles) Track Detents Housing Rotor Wiper Terminal Type: SNP or SNJ.	
				Tol. A: ±5% B: ±10% C: ±20% D: ±30% E: +50%/-30%		Packaging Blank: Bulk R: Tape&Reel		Accessories Assembly (Shaft & Wheel) Ref# Color Flam Connect Operating temperature	
		Taper A: Linear B: Logarithmic C: Antilogarithmic							

*Please contact CTS representatives for the special requests.

Standard Configuration:	Through-hole	SMD
Dimensions:	9mm	
Protection:	IP 54 (high level of protection against dust and also against water splashing) On request: Self-extinguishable, to meet UL 94 V-0	
Substrate:	Carbon technology	Carbon technology, special for high temperature
Color:	Blue housing + white rotor	Brown housing + grey rotor
Packaging:	Bulk or Tape & Reel	
Wiper position:	at 50% ±15°	
Terminals: *	Straight, without crimping.	
Marking:	Resistive value marked on housing. Others on request.	

* By default, terminals are always straight. CTS can provide crimped terminals (with snap in, “SNP” or “SNJ”) to better hold the component to the PCB during the soldering operation.

SNP

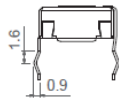

SNJ

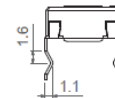

Electrical Specifications

	Through-hole	SMD
Range of resistance values		
Lin (A)	100Ω ≤ Rn ≤ 5MΩ	100Ω ≤ Rn ≤ 1MΩ
Log (B) Antilog (C)	1KΩ ≤ Rn ≤ 2M2Ω	1KΩ ≤ Rn ≤ 1MΩ
Tolerance		
Rn < 100Ω:	+50%, -30% (out of range)	-
100Ω ≤ Rn ≤ 100KΩ:	±20%	±30%
100K < Rn ≤ 1MΩ:	±20%	±40%
1MΩ < Rn ≤ 5MΩ:	±30%	±50%
Rn > 5MΩ:	+50%, -30% (out of range)	-
Variation laws	Lin (A), Log (B), Antilog (C). Other tapers available on request	
Residual Resistance	Rn ≤ 400Ω ≤ 2Ω; Rn > 400Ω 5*10 ⁻³ * Rn	
CRV - Contact Resistance Variation (dynamic)	Lin (A) Electrical Angle 220° ± 20° ≤ 3%Rn. Other tapers, please inquire	
Max. Power Dissipation	at 50°C 0.15W Lin (A) 0.10W Log (B) Antilog (C)	
Max. Voltage	200VDC Lin (A) 150VDC Log (B) Antilog (C)	
Operating temperature	-25°C ... +70°C (+85°C on request)	
Temperature Coefficient		
100Ω ≤ Rn ≤ 10KΩ	+200 / -300 ppm	+200 / -500 ppm
10KΩ ≤ Rn ≤ 5MΩ	+200 / -500 ppm	+200 / -1000 ppm

* Out of range ohm values and tolerances are available on request.

Mechanical and Environmental

Actuation Life	1,000 cycles. On Request: Long Life
Angle of rotation (mechanical)	240° ± 5°
Angle of rotation (electrical)	220° ± 20°
Wiper standard delivery position	50% ± 15°
Max. stop torque	5 Ncm
Max. push/pull on rotor	40 N
Wiper Torque	< 2Ncm Potentiometer with detents: < 2.5 Ncm

Recommended Soldering Conditions (Lead free, RoHS compliant)

Manual soldering	Reflow soldering SMD	Flow (wave) soldering
Soldering tools of 20W max.	Preheating temperature: Max 150°C; 60-90 s	Recommended Alloy: SnAgCu
Maximum temperature of soldering tools: 280°C	Temperature Ramp-up: 2-3°C / s.	Preheating stage: Max 100°C; 30-60 s.
Time: 3 s. max.	Over 220°C:<40 s.	Temperature Ramp-up:1.2-2.5°C/s.
	Solder temperature: 240°C for 5 ± 1 s.	Max. wave temp.: 260°C for 4s., (245°C recommended)
		Time within +0°-10°C of peak: 10s.
		Cooling rate: 5°C/s.

Tapers

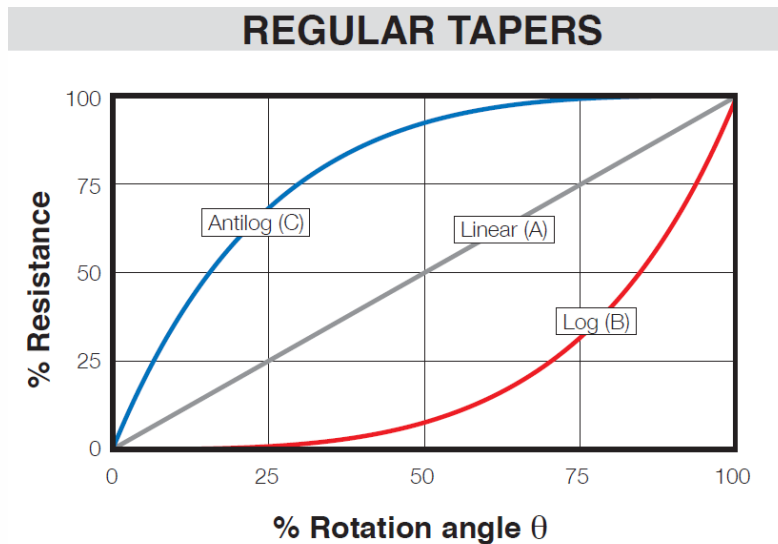

Mechanical Specifications

Rotor

Rotors are drawn in their standard positioning, 50% of rotation. Alternative delivery positioning can be requested. Accessories in this catalogue are designed for the M rotor, unless otherwise stated.

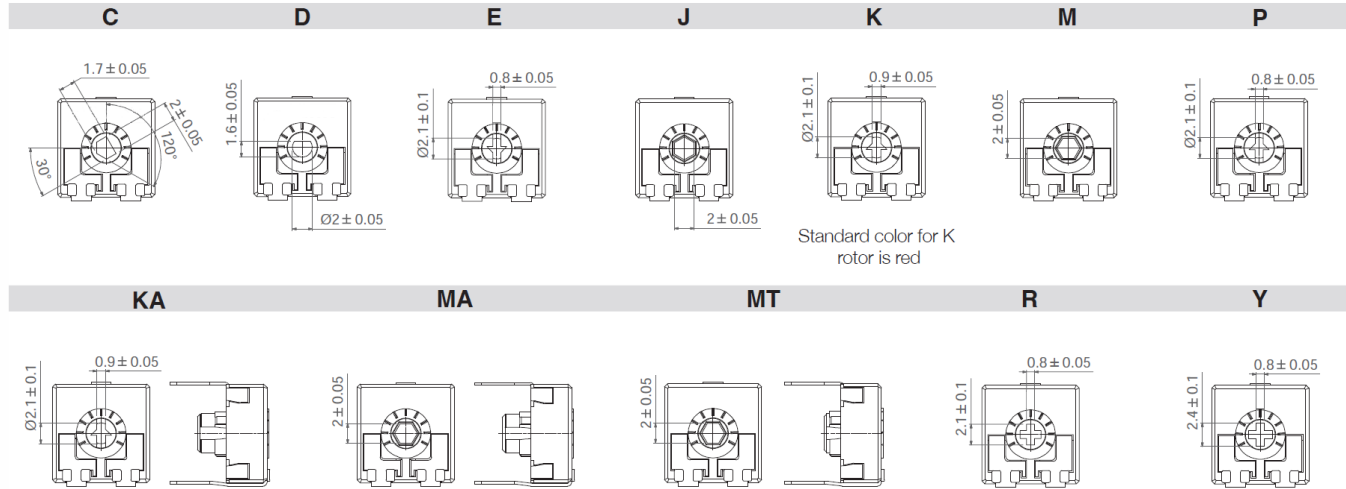

Surface Mount Gull wing Terminal

HSMD

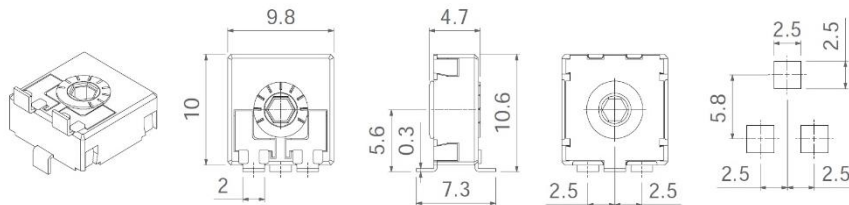

Surface Mount J-bend Terminal

VSMC

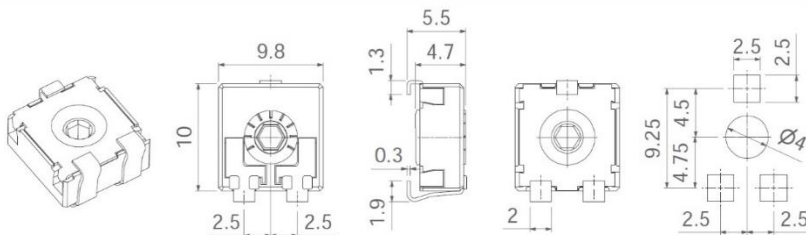

VSMD...CY

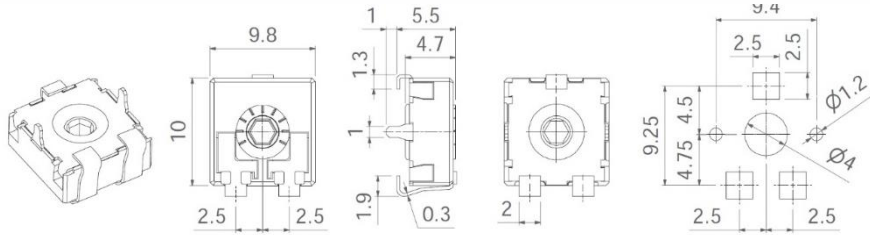

Through-Hole Terminal

H2.5

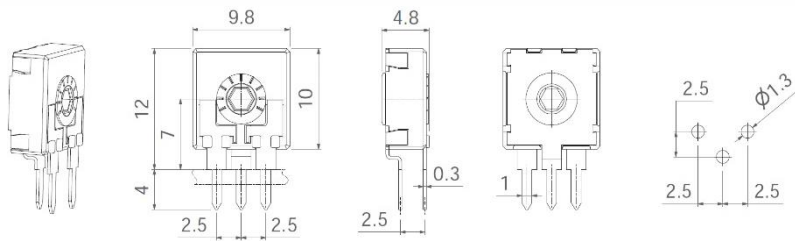

H3.8

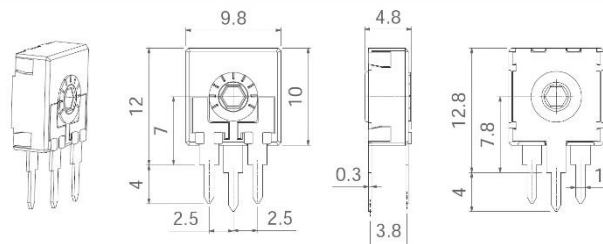

HS3.8

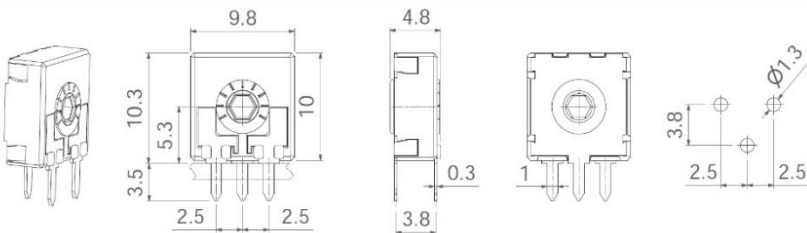

H5

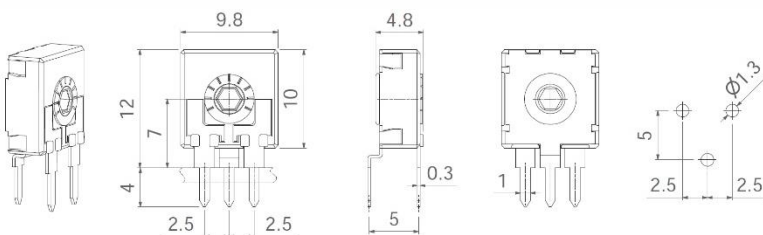

V7.5

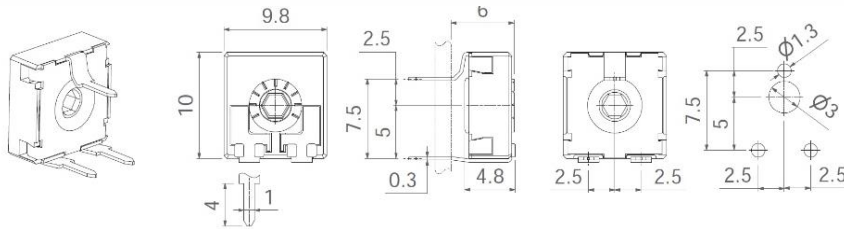

V10

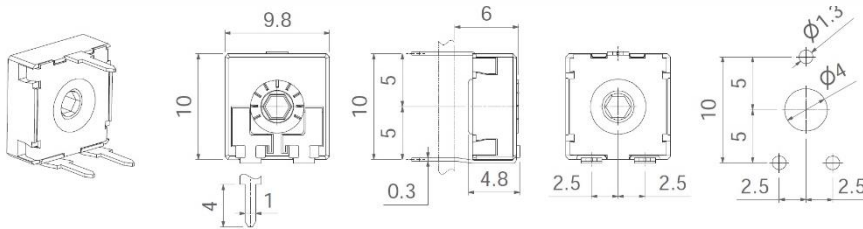

VR10

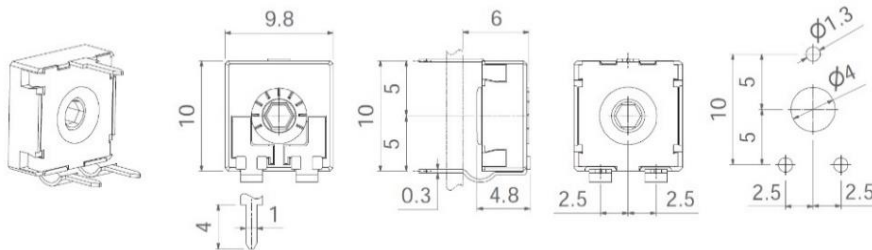

VK10

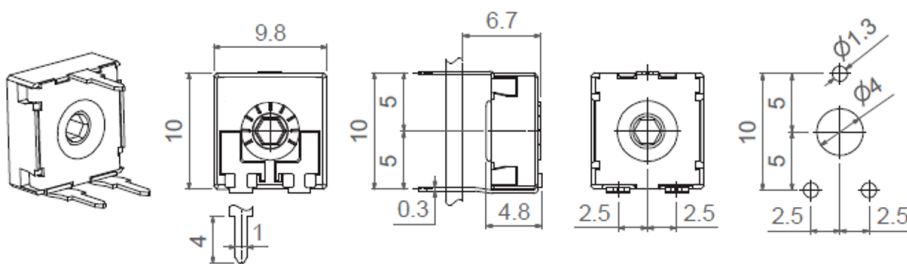

9004

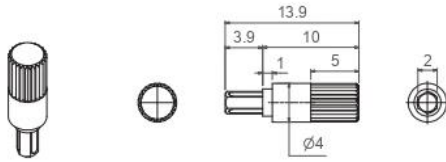

9005

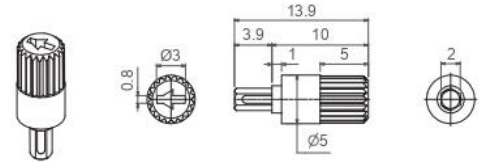

9039 (for 4 ganged potentiometers)

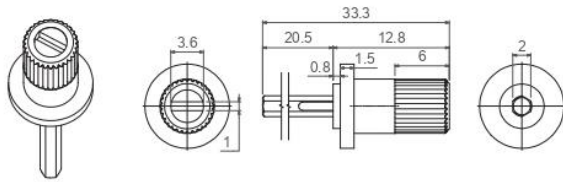

9047

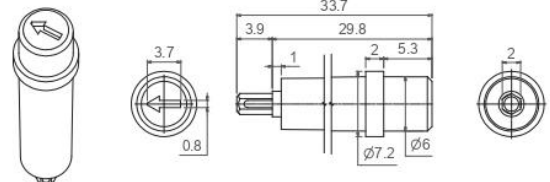

9048 (for 2 ganged potentiometers)

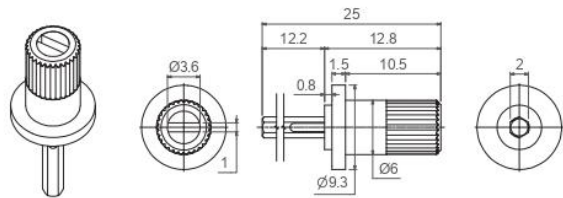

9051 (for 4 ganged potentiometers)

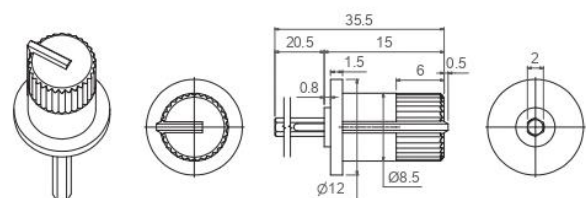

9053

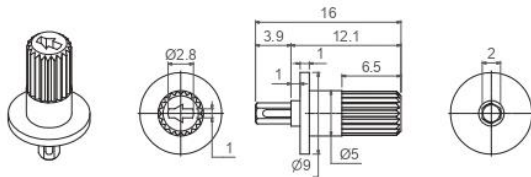

9054

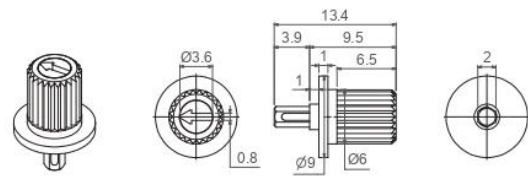

9055

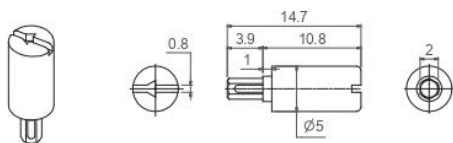

9056 (for 8 ganged potentiometers)

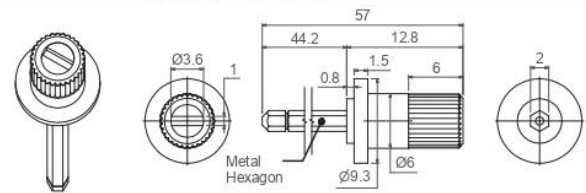

9059

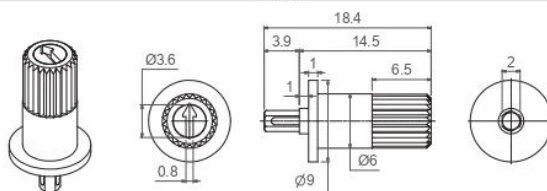

9063

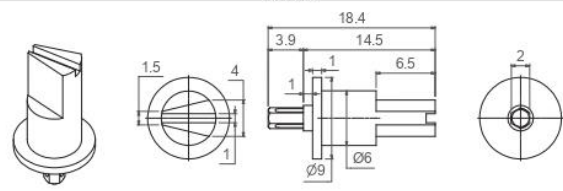

The arrow is in line with the wiper when potentiometer has rotor J (with M rotor, there is a 30° difference).

Wheel

Thumbwheels are available in different colors and with self-extinguishable property according to UL 94 V-0, under request. Thumbwheels can be mounted on the potentiometers at CTS or sold separately. CTS can study special thumbwheel designs.

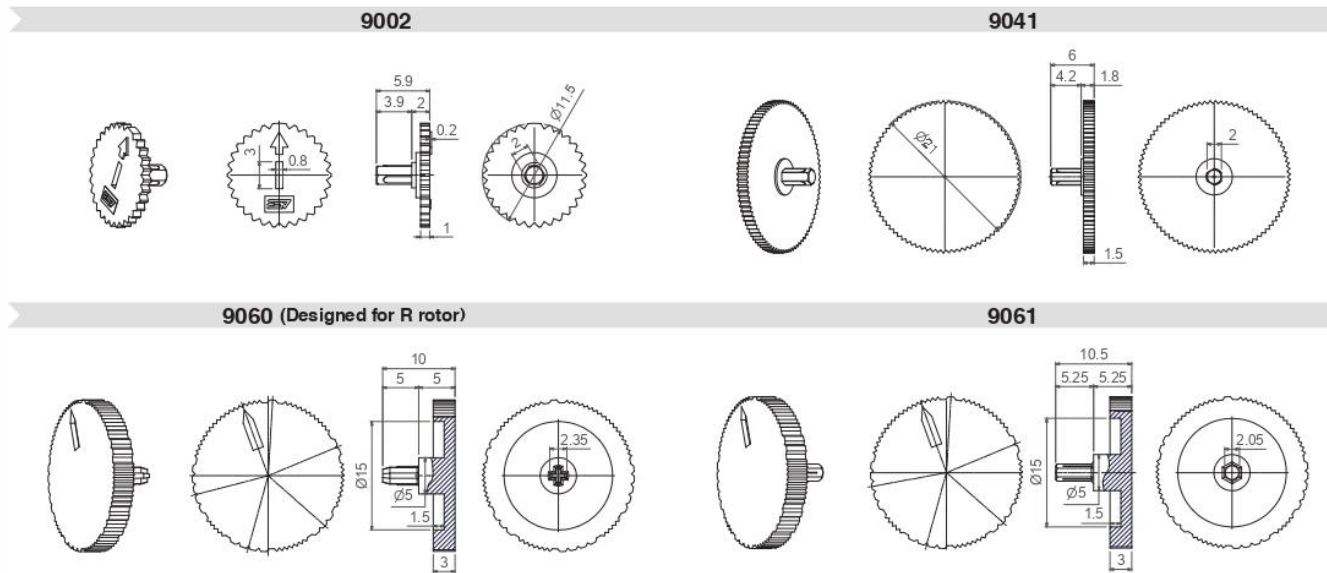

Packaging

Bulk packaging:	With shaft or thumbwheel inserted	Pieces per box
H2,5 - H3,8 - HS3,8 - H5 HSMD - V7,5 - V10 VK10 - VR10 - VSMD	None, only potentiometers.	1000
	9002	750
	9004, 9005, 9006, 9009, 9010, 9018, 9039, 9041, 9047, 9048, 9051, 9053, 9055, 9056, 9059, 9060, 9061, 9063, 9064, 9067, 9070.	450
	9054	500
Tape & Reel packaging:	With thumbwheel inserted?	13" Reel (Standard), with 24mm width tape
VSMD	None, only potentiometers.	900 pcs per reel, 12mm step between cavities.
	9002	700 pcs per reel, 12mm step between cavities.
VSMD...CY	None, only potentiometers.	750 pcs per reel, 12 mm step between cavities
	9002	To be determined
HSMD		350 pcs per reel, 16 mm step between cavities
H2,5...PIP TP25 - H5...PIP TP25 - HS3,8... PIP		250
V7,5...PIP - V10...PIP - V10...PIP TP25 - VR10...PIP	None, only potentiometers or 9002.	250

VSMD-T&R

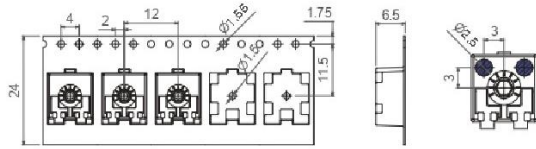

VSMD-T&R...WT-9002

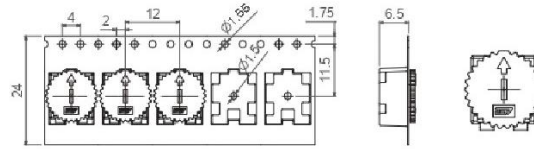

VSMD-T&R...CY

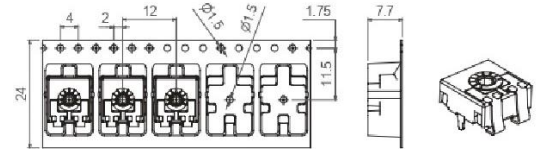

VSMD-T&R...CY WT-9002

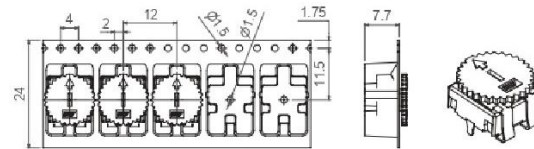

HSMD-T&R

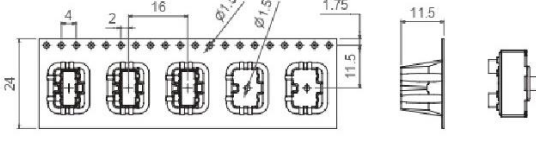

13" Reel

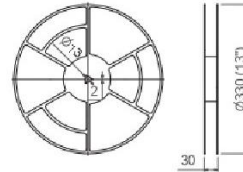

V7,5-T&R...PIP

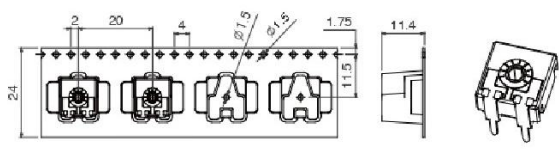

V7,5-T&R... PIP WT-9002

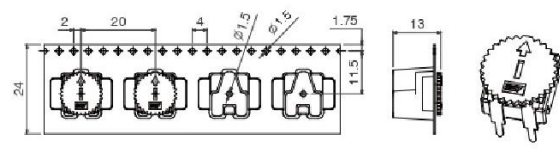

V10-T&R... PIP

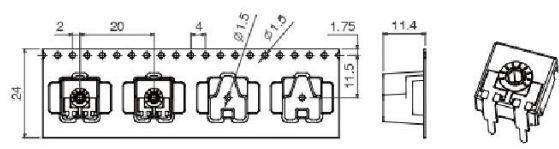

V10-T&R...PIP WT-9002

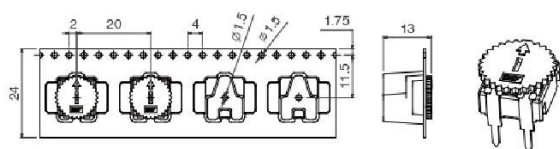

V10-T&R...PIP TP25

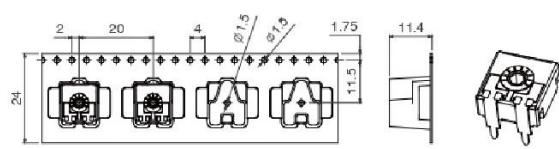

V10-T&R...PIP TP25 WT-9002

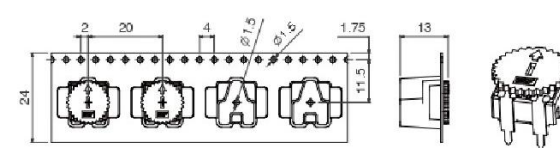

VR10-T&R...PIP

VR10-T&R... PIP WT-9002

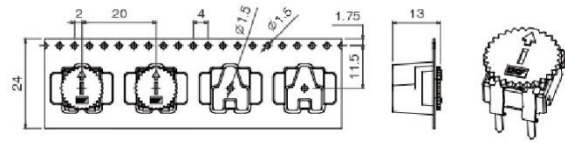
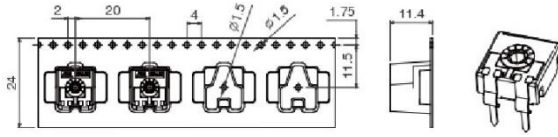

HS3,8-T&R... PIP

H5-T&R...PIP TP25

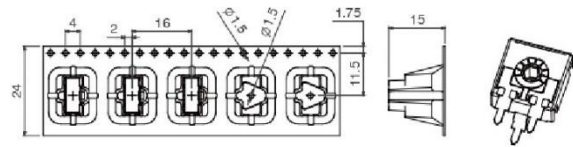
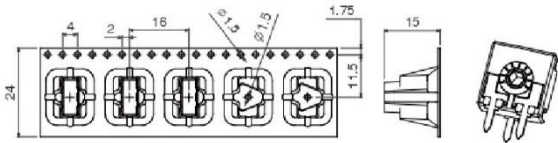

H2,5-T&R...PIP TP25

